

### CHARGER OPERATION

The RTIC-2405 is fully automatic once installed properly. The indicator lights (LEDs) inform the user of the progress of the charging cycle and confirm proper connections.

### ELECTRICAL CHARACTERISTICS

AC Input Voltage Range: 180-250VAC  
 AC Input Current: 3A rms Maximum  
 Max. Charging Current: 5.5 A (Fast Mode)  
 Max. Charging Voltage (Absorption Mode): 58.4-59.4VDC  
 Max. Float Voltage (Float Mode): 53.6-54.81VDC

### LED INDICATORS

Charging Mode: Indicates the state of charge of the battery. The green Float light indicates the battery is fully charged.

Charging current LEDs indicate amount of current.

AC Power On LED indicates AC power is applied to the charger.

Charging Status LED indicates the output is connected properly to the battery and is being charged.

### PROTECTION MODES:

**Over Temperature:** The unit inhibits until it cools off and then restarts automatically. This is indicated by the AC Power and Float LEDs flashing. In very high ambient temperatures, it is possible for the non-auto reset thermal protection to activate. This is indicated by the AC Power on and 7-10 Amp Charging Current LEDs flashing. If this occurs the AC power should be disconnected and reconnected once the charger has cooled off.

**Over Voltage:** Activates in the event of a regulation malfunction and inhibits the charger. An over voltage condition is indicated

### Signal Connector Pin Assignments

Pin No.	Signal	Description
2,8	AC Fail	AC < 170VAC
3,9	DC High	DC > 61VDC
4,10	DC Low	DC < 22VDC
1,7	Charger Fail	Unit Failed
11	TC Data	Temp Sense Data Line
12	TC Rtn	Temp Sense Bias Rtn
6	TC Bias	Temp Sense Bias Power

by the AC Power On and Fast LEDs flashing. If the over voltage persists then the factory should be consulted.

### RELAY CONTACTS

Up to four relay contacts are provided depending upon the option purchased. The relay specification is available on our web page. Please observe relay specifications in order to maintain proper operation. Contacts are closed for a true condition.

### Temperature Compensation

The temperature compensation pod can be tie-wrapped to the charger cable in the immediate vicinity of the battery or wall mounted. Compensation is 15mV-18mV per degree Celsius per cell.

### Outline and Mounting

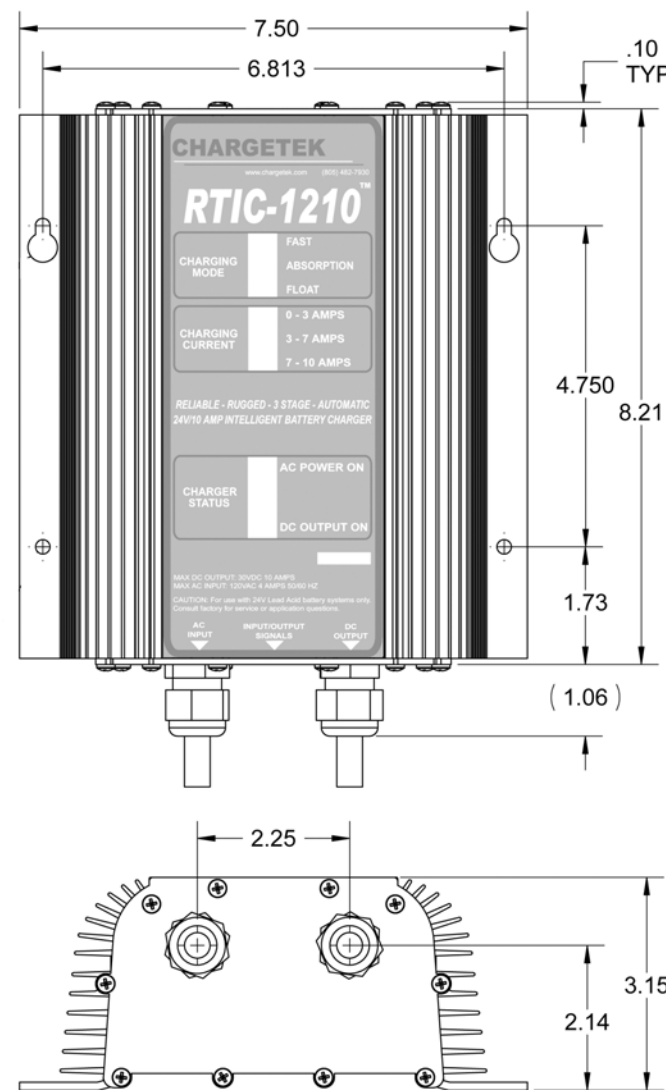

# CHARGETEK

## RTIC-2405-WP

### INSTALLATION MANUAL

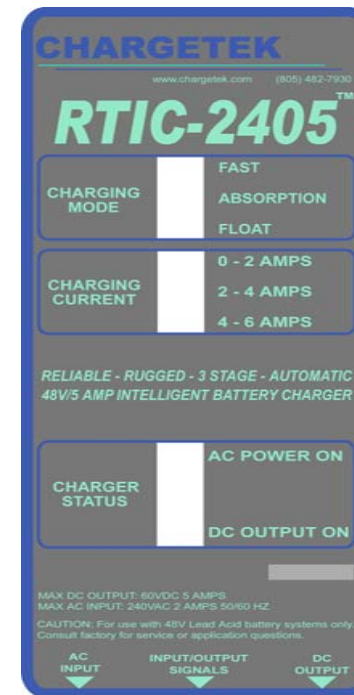

The RTIC-2405 is a rugged, waterproof and sophisticated three state lead-acid battery charger. With a wide operating temperature range (-10C to 60C) and UL/CSA1236 certification, this product is especially suited for high end industrial applications and severe environments.

The RTIC-2405 is factory programmable to accommodate several charging algorithms, an LED display to indicate status, and an optional four relay contact pack to indicate various scenarios. Temperature compensation is implemented digitally allowing ac-

curate and noise free sensing up to a distance of 300 feet eliminating problems associated with conventional analog approaches.

Charging operation, LEDs, and relay control signals are generated by an embedded microcontroller that contains software developed by and proprietary to Chargetek. The RTIC-2405 precisely controls charging voltage and current to insure a complete recharge every time. The charger may be left connected indefinitely to the battery, maintaining full charge at all times.

### LIMITED WARRANTY

For two years from date of manufacture, Chargetek Inc. will at its discretion repair or replace for the original consumer, free of charge any part or parts found to be defective by Chargetek in workmanship or material. All shipping charges under warranty must be paid by the consumer. Proof of purchase is required. There is no other expressed warranty. Implied warranties, including those of merchantability and fitness for a particular purpose are limited to two years from the date of purchase. This is the exclusive remedy and consequential damages are excluded where permitted by law.

### CHARGETEK

409 Calle San Pablo, Unit 104 ~ Camarillo, CA 93012 ~ PHONE: (866) 482-7930 FAX: (805) 482-7936

WWW.CHARGETEK.COM

# INSTALLATION

## LOCATION

- ❑ Do not mount directly over or under a battery or onto a carpeted, upholstered or varnished surface.
- ❑ Install in an area where all charger electrical cords will avoid hot surfaces such as exhaust pipes and moving parts such as fan wheels.
- ❑ Operating temperature is -10C (14F) to 60C (160F) degrees Celcius.
- ❑ Provide as much surrounding cooling clearance as possible. At a minimum, maintain an 8 inch clearance around the perimeter and top side of the charger.
- ❑ Never mount in the vicinity of explosives, pressurized cans or other flammable material.

## MOUNTING

- ❑ Wear safety goggles, gloves and a long sleeve shirt when drilling mounting holes near a battery.
- ❑ In most cases, #10 stainless steel mounting bolts with aircraft nuts or nylocks or #10 screws provide for solid mounting.

## ELECTRICAL

### DC WIRE CONNECTIONS

- ❑ The charger should be used only with a lead-acid type battery.
- ❑ DC wire connections to the battery should be made before plugging in the AC cord. Do not remove DC connections while the AC cord is plugged in.
- ❑ When installing in the bilge and or battery compartment of boats, open hatches and operate bilge blowers if any for ten minutes to remove any fumes and hydrogen gas. Be certain the area is ventilated for personal health and safety.
- ❑ Keep wire routing from the charger to the battery neat and secure by anchoring with cable tie to a solid surface every few inches, not to exceed 18" intervals.

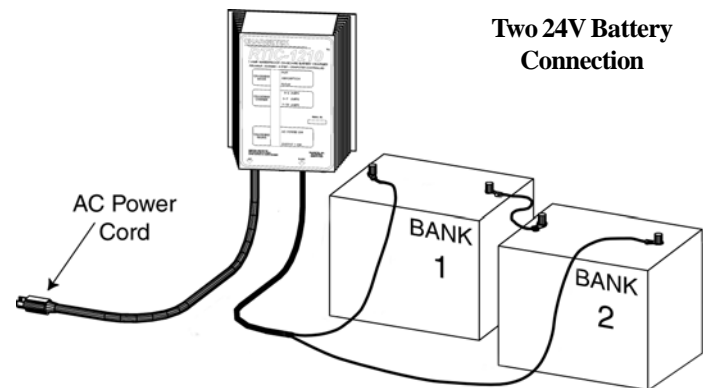

- ❑ As is true with any device connected to a battery, an in-line fuse added to the positive lead to the battery is required and will provide further protection if the DC cord is somehow damaged.
- ❑ For a single 24 volt battery, connect the charger lead set to the battery as follows; the charger red lead is connected to the battery positive terminal and the black charger lead is connected to negative terminal of the battery. When charging two 12 volt batteries connected in series connect the red lead of the charger to the positive terminal of battery #1. Connected the negative terminal of battery #1 to the positive terminal of battery #2. Connect the black lead of the charger to the negative terminal of battery #2. All connections should be clean and tight. See installation diagrams.
- ❑ When connecting two batteries in series it is imperative that the amount of discharge be equal for both batteries or excessive battery voltage during charge will occur resulting in an overvoltage battery. This will cause dangerous battery out gassing and destruction. For accurate charge balancing regardless of loading use the TPRO220 or TPRO320 model.

### AC Wire Connections

#### Note:

*The Chargetek RTIC -2405 is equipped with a factory installed 6' grounded AC cord. Though hook up is only a matter of plugging this cord into a suitable extension cord, please follow the following precautionary tips.*

- ❑ Insure that the AC cord cannot reach moving parts, lids, hoods, etc. Secure with a cable tie to solid anchor point if necessary.
- ❑ The charger will operate properly with either 115 volts 50 Hz or 115 volts 60 Hz AC input. Never use 220 volt service with this unit.

#### CAUTION:

*Never connect the AC plug into an electrical outlet when you are wet or barefoot.*

### Single 48V Battery Connection

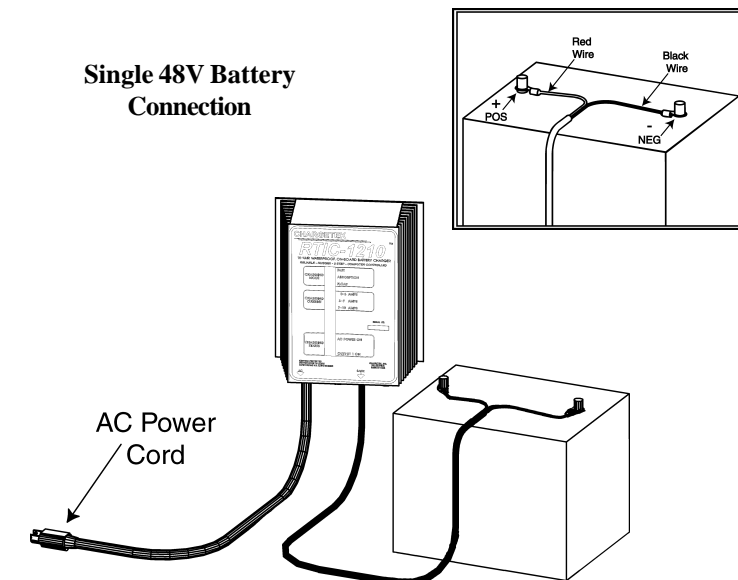

# SAFETY INSTRUCTIONS

**CAUTION:** *The following are important safety instructions. Save these instructions.*

- ❑ Charge only lead acid, (maintenance free or refillable), or "gel-cell" rechargeable batteries. Other types of batteries may burst causing personal injury and damage
- ❑ Never smoke or allow sparks or flame in the vicinity of a battery.
- ❑ Someone should be within range of your voice and close enough to come to your aid when you are working near a battery.
- ❑ Wear eye protection and clothing protection. Avoid touching eyes while working near a battery.
- ❑ Have plenty of fresh water and soap nearby in case battery acid contact's skin, clothing or eyes.
- ❑ If battery acid contact's skin or clothing, wash immediately with soap and water. If acid enters eyes, immediately flood eyes with running cold water for at least ten minutes and get immediate medical attention.
- ❑ Never operate a charger with a damaged cord or plug. Wearing of AC and DC cords, accidentally nicking or cutting the cords could result in sparking and cause injury.

- ❑ Never operate a charger that has been damaged in any way or try

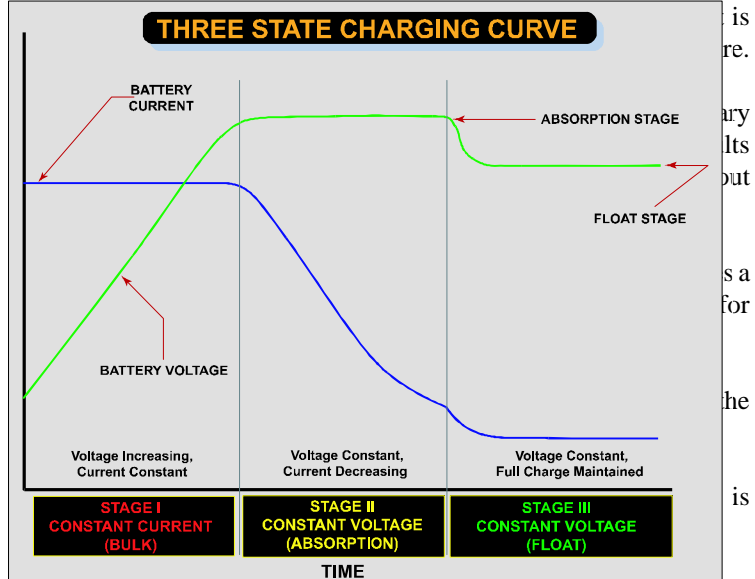

- ❑ Study battery manufacturer's precautions such as removing or not removing cell caps while charging.
- ❑ Keep batteries full. Add distilled water in each cell until it reaches levels specified by battery. Check battery fluid levels regularly.
- ❑ Keep battery terminals clean. Always unplug charger before cleaning and be careful to keep corrosion from coming in contact with eyes.

- ❑ Remove personal metal items such as rings, bracelets, necklaces, and watches when working with a lead-acid battery. A lead-acid battery can produce a short circuit high enough to weld a ring, etc. to metal, causing a severe burn.

## THREE STATE CHARGE CYCLE

The RTIC-2405 employs a three state charge routine. This is the charging procedure most lead-acid battery manufacturers recommend to return full capacity efficiently and extend battery life. Please refer to the figure Three State Charging Curve diagram.

### STAGE I: CONSTANT CURRENT CHARGING OR BULK CHARGE MODE

Assuming the battery is starting in a discharged state, the charging is operating in constant current mode, where the charger current is maintained at a constant value and the battery voltage is allowed to rise as it is being recharged. Approximately 80% of battery capacity is returned in the constant current region.

### STAGE II: ABSORPTION MODE

When the battery voltage reaches approximately 2.4 volts per cell, or 28.8 volts for a 24V battery, the charger voltage is held constant at this level and the battery current is allowed to reduce. This voltage is maintained until the charging current reduces substantially indicating a full charge. At this point the battery is fully charged.

### STAGE III: FLOAT MODE

Float mode is the final stage of the charging routine. Float mode is where the voltage on the battery is maintained at approximately 2.25 volts per cell, or 27.0 volts for a 24V battery. This voltage will maintain the full charge condition in the battery without boiling out electrolyte or overcharging the battery. When the charger is in this mode all lights on the RTIC-2405 should be green.